

For Keysight Digital and Mixed Signal Oscilloscopes

USB Power Delivery Compliance Test Software (GRL-USB-PD) and USB Type-C™ Test Controller (GRL-USB-PD-C1)

Quickly run USB Power Delivery (USB-PD) compliance and Validation Tests with Keysight Windows-based Oscilloscopes



Product Overview

GRL's USB Power Delivery (GRL-USB-PD) Compliance Test Software is the world's first oscilloscope-based software tool designed for testing to the USB Power Delivery (USB-PD) Specification. GRL-USB-PD software, when used 'stand-alone' on any Windows based oscilloscope, provides a simple and efficient way to perform USB-PD electrical parametric and protocol measurements. GRL-USB-PD provides waveform visibility and protocol analysis, making it ideal for design and debug of USB Type-C Power Delivery silicon and end products.

When used with GRL's USB Type-C Test Controller (GRL-USB-PD-C1), GRL-USB-PD provides a complete, automated solution for Compliance Testing to the USB Power Delivery Compliance Plan.

GRL has been a contributor to the USB Power Delivery Specification and Compliance Working Groups since mid-2014. With GRL's USB-PD Compliance Solution, you can perform the required USB-PD Compliance tests in your own lab before attending a workshop or sending your device to a lab for Compliance.



For most new designs using the USB Type-C Connector, the USB-PD Specification provides the handshaking contract needed for power delivery, and for 'Alt Mode' entry and exit into other technologies, such as DisplayPort™ and Thunderbolt™ 3. GRL's flexible controller and software solution supports the validation of Alt Mode link negotiation. The GRL-USB-PD-C1 Type-C Test Controller can also be used with a high performance oscilloscope to initiate Alt Mode for high-speed PHY testing.

- » Performs Compliance Tests for any USB Power Delivery or Type-C design
- » Tests USB Power Delivery Bi-Phase Mark Codes (BMC) Physical Layer (PHY), Protocol (PROT), and Power Provider/Consumer (POW) Compliance
- » Supports USB Power Delivery Protocol, Compliance, Decode, and Debug along with Electrical Measurements
- » Validates Alt Modes' Entry/Exits over USB Type-C.
- » Runs on Windows-based Oscilloscopes

GRL-USB-PD provides an essential analysis and compliance tool for the design, debug, and compliance testing of USB Power Delivery and USB Type-C designs.

Features

- » Runs on Keysight Windows-based oscilloscopes
- » Conforms to the latest USB-IF USB-PD Specification and Test Plans
- » Performs electrical physical layer (BMC-PHY) tests - Chapter 5 of the Specification
- » Performs protocol layer (BMC-PROT) tests - Chapter 6 of the Specification
- » Performs power state (BMC-POW) tests - Chapter 7 of the Specification
- » Fully automates all tests required for USB-PD Certification
- » Tests full range of USB-PD devices - Cable 'eMarkers', Providers, Consumers, Dual-Role Devices
- » Provides direct linkage and traceability of packet data to the USB-PD physical layer signal
- » Automatically saves all waveforms for further analysis and debug
- » Fully automates the test process from Product Registration to Certification Approval
- » Automatically generates comprehensive test reports - .pdf, .csv and .xml files
- » Supports 'Alt Mode' Initiation for high-speed Physical Layer (PHY) testing

Rear Panel



Front Panel

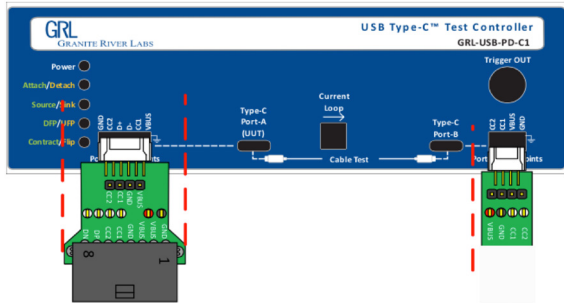

Flexible USB Type-C Test Controller

GRL-USB-PD-C1 is a flexible test controller, designed for USB-PD Compliance testing of the Unit Under Test (UUT) and more.

Rear Panel

- » eLoad -- Connects to external Electronic Load for load testing of the UUT.
- » Power -- Provides options to the Power Controller and UUT
- » USB Control -- USB 3.0 Control Connection to Windows-based oscilloscope
- » Type-C SBU -- Input of SBU Signal. Output appears on Type-C Port A Connector
- » System -- External connection to upgrade FPGA Firmware

Front Panel

- » Indicator LEDs -- Power, Attach/Detach, Source/Sink, DFP/UFP, Contract/Flip
- » Type-C Port A -- Primary connection for UUT
- » Type-C Port B -- Secondary connection for Cable testing
- » Port A Probe Points -- Probe Port A (Gnd, CC1, D+, D-, CC, Vbus) with external adapter, including Interface Adapter for high-speed test fixtures.
- » Port B Probe Points -- Probe Port B (Gnd, CC1, CC2, Vbus) with external adapter
- » Trigger Out -- Event Trigger for oscilloscope

Fully-Automated Compliance Test Process

GRL-USB-PD software automates USB-PD Compliance Testing using GRL's Automation Framework. Compliance testing is streamlined by importing device capabilities from a user-created 'Vendor File'. Device Capabilities are then validated against the device's USB-PD Vendor Defined Message (VDM). The test plan is automatically created and executed, based on device capabilities. After testing is complete, the report is created in multiple file formats for further data analysis. Reports can be shared in industry or engineering group databases.

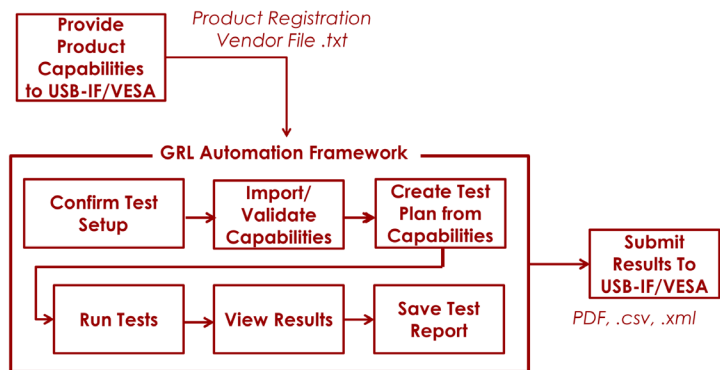

USB-PD 'eMarker' Cable Testing

The USB Type-C and USB-PD Specifications require all Fully Featured Cables and Adapters to have an eMarker Chip. Cable eMarker Compliance testing must be done at the component level and for end products. To perform Cable eMarker testing, simply plug one end of the Cable into Port A on the GRL-USB-PD-C1 Controller, and run the tests in the GRL-USB-PD software. The IR drop of a Cable can also be tested by applying a load current and measuring the Vbus drop between Port A and Port B.

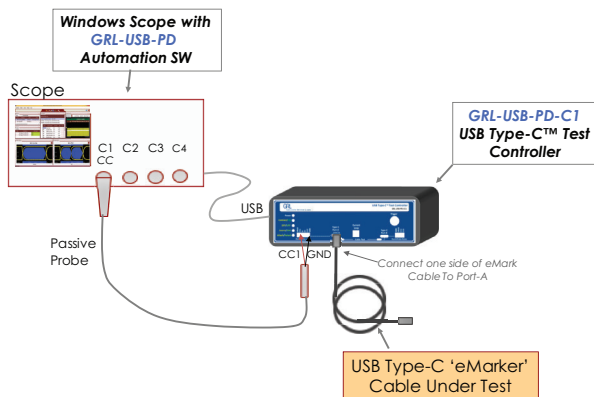

Test Ref #	Test Name	Test Description
Primary Cable Marker Tests		
CABLE PHYSICAL LAYER TESTS - TRANSMIT		
TDA.1.1.1.1.1	CAB-PHY-TX-EYE	Cable Transmitter Eye Diagram Test (SOP Prime)
TDA.1.1.1.1.2	CAB-DP-PHY-TX-EYE	Cable Transmitter Eye Diagram Test (SOP Double Prime)
TDA.1.1.1.2.1	CAB-PHY-TX-BIT	Cable Transmit Bit Rate and Bit Rate Drift (SOP Prime)
TDA.1.1.1.2.2	CAB-DP-PHY-TX-BIT	Cable Transmit Bit Rate and Bit Rate Drift (SOP Double Prime)
CABLE PHYSICAL LAYER TESTS - RECEIVE		
TDA.1.1.2.1.1	CAB-PHY-RX-BUSIDL	Cable Bus Idle Detection Test (SOP Prime)
TDA.1.1.2.1.2	CAB-DP-PHY-RX-BUSIDL	Cable Bus Idle Detection Test (SOP Double Prime)
TDA.1.1.2.2.1	CAB-PHY-RX-INT-REJ	Cable Receive Interference Rejection Test (SOP Prime)
TDA.1.1.2.2.2	CAB-DP-PHY-RX-INT-REJ	Cable Receive Interference Rejection Test (SOP Double Prime)
CABLE PHYSICAL LAYER TESTS - MISCELLANEOUS		
TDA.1.1.3.1.1	CAB-PHY-TERM	Cable Termination Impedance Test (SOP Prime)
TDA.1.1.3.1.2	CAB-DP-PHY-TERM	Cable Termination Impedance Test (SOP Double Prime)
TDA.1.1.3.2.1	CAB-PHY-MSG	Cable PHY Level Message Test (SOP Prime)
TDA.1.1.3.2.2	CAB-DP-PHY-MSG	Cable PHY Level Message Test (SOP Double Prime)
CABLE PROTOCOL SPECIFIC TESTS		
TDA.1.2.1	CAB-PROT-DISCOV	Cable ID Checks

USB -PD Test Suite

GRL-USB-PD software with the GRL-USB-PD-C1 controller support a long list of Primary and Secondary Tests. The USB Power Delivery Specification defines USB Hosts and Devices as Power Providers, Power Consumers, or Dual Role Power Devices. A Dual Role device can be primarily a Provider (P/C), or a Consumer (C/P). There are as many as 23 Primary Tests (listed below) and up to 45 Secondary Tests (not listed) required for Certification. The number of tests run on a device depends on the type of device and its capabilities. The GRL-USB-PD software provides a few easy steps for the user to define a test plan, and then fully automates all the tests.

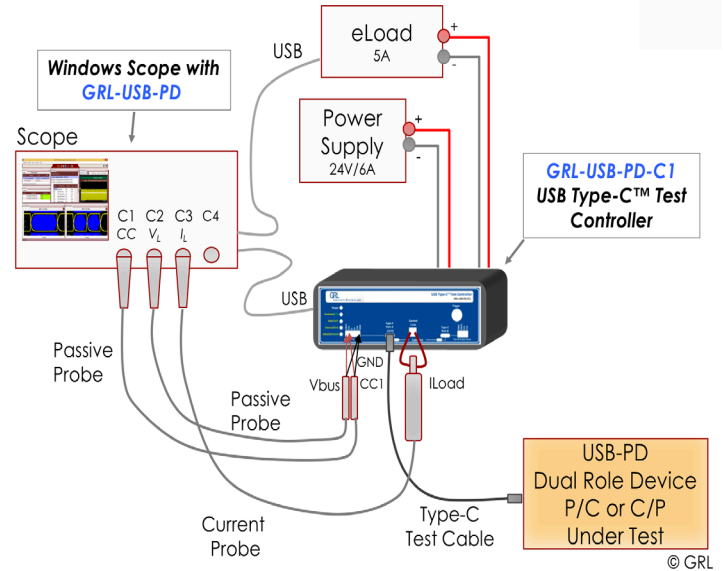

Test Ref #	Test Name	Test Description	Required Tests by Device Type				
			DRP	Provider Only	Consumer Only	Dual Role Device	
						C/P	P/C
Primary Power Delivery Device Tests							
Power Rules Tests							
PDSPEC10.10.2	SOURCE-POWER-RULES	Source Power Rules Test	✓	✓		✓	✓
PDSPEC10.10.3	SINK-POWER-RULES	Sink Power Rules Test	✓		✓	✓	✓
BMC PHYSICAL LAYER TESTS - TRANSMIT							
TDA.2.1.1.1	BMC-PHY-TX-EYE	BMC Transmitter Eye Diagram Test	✓	✓	✓	✓	✓
TDA.2.1.1.2	BMC-PHY-TX-BIT	BMC Transmit Bit Rate and Bit Rate Drift	✓	✓	✓	✓	✓
BMC PHYSICAL LAYER TESTS - RECEIVE							
TDA.2.1.2.1	BMC-PHY-RX-BUSIDL	BMC Bus Idle Detection Test	✓	✓	✓	✓	✓
TDA.2.1.2.2	BMC-PHY-RX-INT-REJ	BMC Receive Interference Rejection Test	✓	✓	✓	✓	✓
BMC PHYSICAL LAYER TESTS - MISCELLANEOUS							
TDA.2.1.3.1	BMC-PHY-TERM	BMC Termination Impedance Test	✓	✓	✓	✓	✓
TDA.2.1.3.2	BMC-PHY-MSG	BMC PHY Level Message Test	✓	✓	✓	✓	✓
PROTOCOL SPECIFIC - Message Checks							
TDA.2.2.1	BMC-PROT-SEQ-GETCAPS	Get_Source_Cap and Get_Sink_Cap Test	✓	✓	✓	✓	✓
TDA.2.2.2.1	BMC-PROT-SEQ-CHKCAB-P-PC	Check Cable Capabilities (3A Marked) Test	✓	✓		✓	✓
TDA.2.2.2.2	BMC-PROT-SEQ-CHKCAB-NOMRK-P-PC	Check Cable Capabilities (Unmarked) Test	✓	✓		✓	✓
TDA.2.2.2.3	BMC-PROT-SEQ-CHKCAB-CP-ACC	Check Cable Capabilities (3A Marked) Test - After PR Swap	✓			✓	
TDA.2.2.2.4	BMC-PROT-SEQ-CHKCAB-NOMRK-CP-ACC	Check Cable Capabilities (Unmarked) Test - After PR Swap	✓			✓	
TDA.2.2.3	BMC-PROT-SEQ-DRSWAP	Dual Role Swap Test	✓	✓	✓	✓	✓
TDA.2.2.4	BMC-PROT-SEQ-VCSWAP	VCONN Swap Test	✓	✓	✓	✓	✓
TDA.2.2.5	BMC-PROT-DISCOV	ID Checks	✓		✓	✓	
TDA.2.2.6	PROT-SEQ-SWAP-REJ	Reject Swap Test - Provider/Consumer	✓				✓
TDA.2.2.7	BMC-PROT-BIST-NOT-5V-SRC	BIST Functionality at Above 5V Test	>5V DUT Only	>5V DUT Only			>5V DUT Only
TDA.2.2.8	BMC-PROT-REV-NUM	Revision Number Test	✓		✓	✓	✓
Power Source/Sink Tests							
TDA.2.3.1.1	BMC-POW-SRC-LOAD-P-PC	Source Dynamic Load Test, Provider or Provider/Consumer	✓	✓		✓	✓
TDA.2.3.1.2	BMC-POW-SRC-LOAD-CP-ACC	Source Dynamic Load Test, Consumer/Provider Accepting Swap	✓			✓	
TDA.2.3.2.1	BMC-POW-SRC-TRANS-P-PC	PDO Transition Test - Source, Provider or Provider/Consumer	✓	✓		✓	✓
TDA.2.3.2.2	BMC-POW-SRC-TRANS-CP-ACC	PDO Transition Test - Source, Consumer/Provider Accepting Swap	✓			✓	
TDA.2.3.3.1	BMC-POW-SNK-TRANS-C-CP	PDO Transition, Current Draw and Suspend Test - Sink, Consumer or	✓		✓	✓	
TDA.2.3.3.1	BMC-POW-SNK-TRANS-PC	PDO Transition, Current Draw, and Suspend Test, Sink, Provider/Consumer	✓			✓	✓

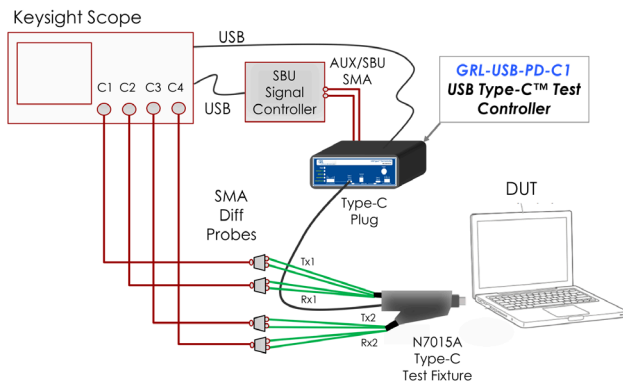

USB Type-C Alt Mode Testing

The USB Type C Specification allows for other technologies to be hosted over the USB Type-C connector. Technologies that have adopted USB Type-C are DisplayPort, and Thunderbolt 3. Each technology has defined its own USB-PD tests for the 'CC' signal path. GRL-USB-PD software supports these tests. Alt Mode must be established before high-speed physical layer (PHY) testing can be performed for those protocols. The GRL-USB-PD-C1 Type-C Test Controller is an essential element for automating high-speed PHY testing.

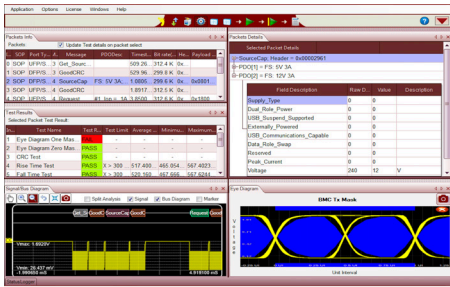

Comprehensive Analysis

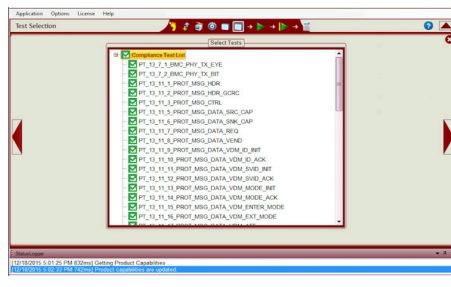

Automatically Generated Test List

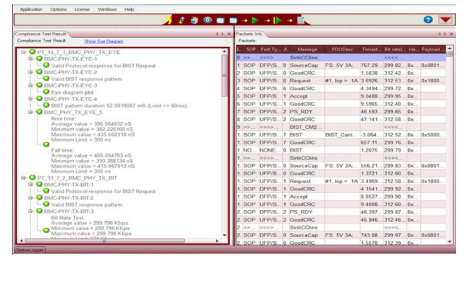

Viewable Test Results prior to Report Generation



Silicon Valley, USA

Hsinchu & Taipei, Taiwan

Bangalore, India

Böblingen, Germany

Singapore

Penang, Malaysia

Beaverton Oregon, USA

Yokohama, Japan

Shanghai, China

Application Specifications

GRL-USB-PD Power Delivery Compliance Solution	
USB Type-C Related Specifications	USB Power Delivery Test Plan for Power Delivery Specification Revision 1.0, Version 2.0 (June 2016) USB Power Delivery Specification Revision 2.0, Version 1.2 (March 2016) USB Type-C Functional Test Specification, Revision 0.70 (January 2016) DisplayPort Alt Mode on USB Type-C, Version 1.0a (August 2015) Thunderbolt Interconnect Specification, USB Type-C Thunderbolt Alternate Mode, Revision 1.5
Supported Oscilloscopes	Infinitiium S-Series, V-Series, Z-Series, 9000 Series, 90000A Series
Required Equipment (for all USB-PD and Type-C Tests)	Keysight Digital Oscilloscope Passive Probes for V_{BUS} and CC Line Capture GRL USB-PD Compliance Software (GRL-USB-PD) GRL Type-C Test Controller (GRL-USB-PD-C1)
Additional Equipment (for Provider and Dual Role Tests)	N2893A Current Probe (or equivalent) Programmable Electronic Load 'eLoad' (N3300 or equivalent): Ranges: 150mA, 900mA, 1.5A, 3A, 5A (20V max) Slew Rate: 150mA/us
Power Options (for Consumer and Dual Role Tests)	GRL-USB-PD-C1 Power Options: Option 1: Power Input 24V DC, 120W External Wall Brick, Standard Option 2: Power Input 24V DC, 120W External Lab Power Supply Option 3: VBUS-In External Programmable Lab Power Supply

Ordering Information

For a formal quote & pricing information, contact info@graniteriverlabs.com, or your Keysight sales representative.

Model Number	Description
GRL-USB-PD	GRL USB Power Delivery Compliance Test Software
GRL-USB-PD-C1	GRL USB Type-C Test Controller - US Power Cord
GRL-USB-PD-C1-EUR	GRL USB Type-C Test Controller - Europe Power Cord
GRL-USB-PD-C1-AUS	GRL USB Type-C Test Controller - Australia Power Cord
GRL-USB-PD-C1-CHN	GRL USB Type-C Test Controller - China Power Cord

GRL
GRANITE RIVER LABS

World Wide Headquarters

Granite River Labs
 3500 Thomas Road, Suite A
 Santa Clara, CA 95054 USA
 +1 (408) 627-7608
info@graniteriverlabs.com
www.graniteriverlabs.com

About Granite River Labs

Granite River Labs (GRL) provides end-to-end Engineering Services and Test Solutions to help hardware engineers adopt high speed interfaces. A trusted partner of small up-and-coming hardware developers to some of the largest companies in the world, GRL combines recognized industry expertise in high performance test equipment, automated test solutions, and convenient locations to provide the utmost in customer service and robust, user-friendly tools. Together with our customers, we overcome challenges with designing and validating early stage products and new connectivity technologies.

For additional information or questions regarding Granite River Labs, including quotes, product demonstrations, software and technical assistance, please contact us at info@graniteriverlabs.com.

© Granite River Labs Asia Pacific Pte. Ltd. All rights reserved. All trademarks used in this document are the property of their respective owners. Product specifications and descriptions in this document subject to change without notice. Contact your sales consultant for the latest information.

GRL-USB-PD. Published June 2016.